

Door installation instructions

Tools Required:

1. Drill
2. 3mm drill bit (supplied)
3. Silicone (supplied)
4. Pozi-drive screwdriver
5. Spirit level
6. Measuring Tape
7. Pencil
8. 6mm masonry bit
9. Saw

PRIOR TO COMMENCING YOUR ASSEMBLY INSTALLATION,
PLEASE READ THESE INSTRUCTIONS CAREFULLY.

Option

A

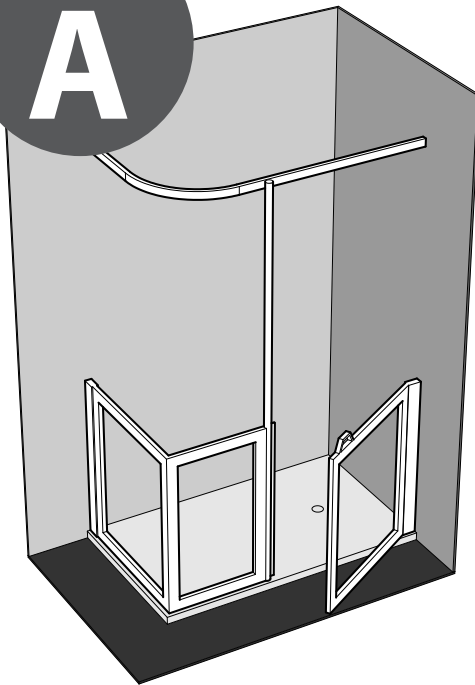

Option

B

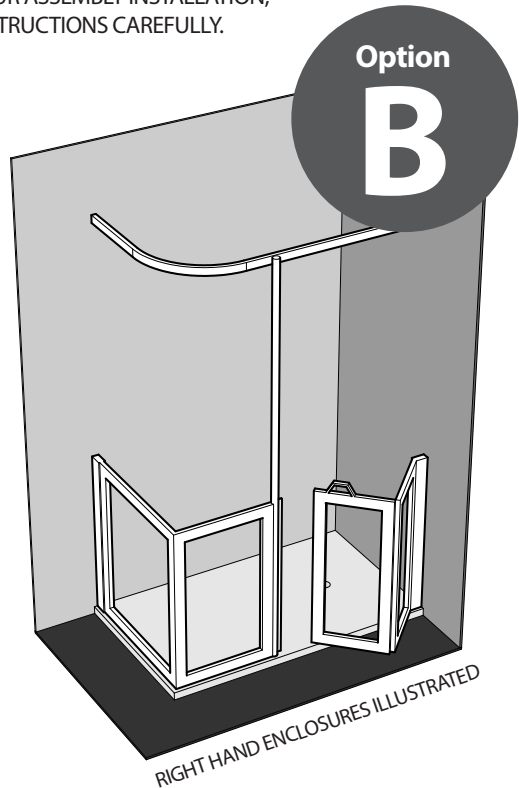

RIGHT HAND ENCLOSURES ILLUSTRATED

adaptocare

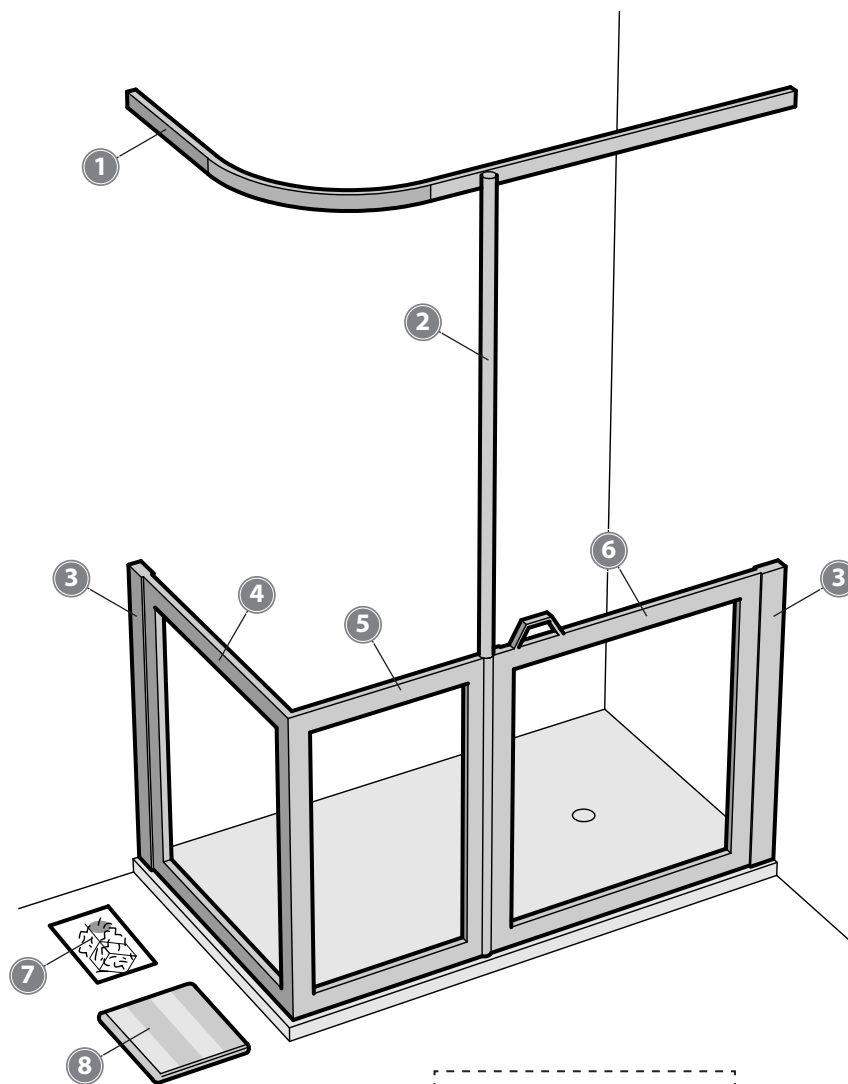

Components:

1. Curtain rail & fittings
2. Vertical support post
3. Compensators (x2)
4. Fixed panel #1
5. Fixed panel #2
6. Door (Option A)
Bi-fold door (Option B)
7. Fittings & fixings
8. Shower curtain

BEFORE BEGINNING INSTALLATION PLEASE CHECK:

1. All component parts of your assembly, including fixings, are present and in good condition. Any shortages or damaged goods should be reported immediately.
2. The shower unit has a suitable flow rate. Power showers are NOT suitable for special needs trays or wet floors.
3. The door seal platform on the tray where the doors sit should be level, i.e. on length and width.

DOOR ALIGNMENT INFORMATION:

When installing your assembly, please be mindful of where the doors sits in relation to the shower tray. The inner face of the doors should be aligned with the inside of the door seal platform (the flat area on the tray where the seal sits).

Failure to install the doors in this position could cause a lower quality of performance from the door seals.

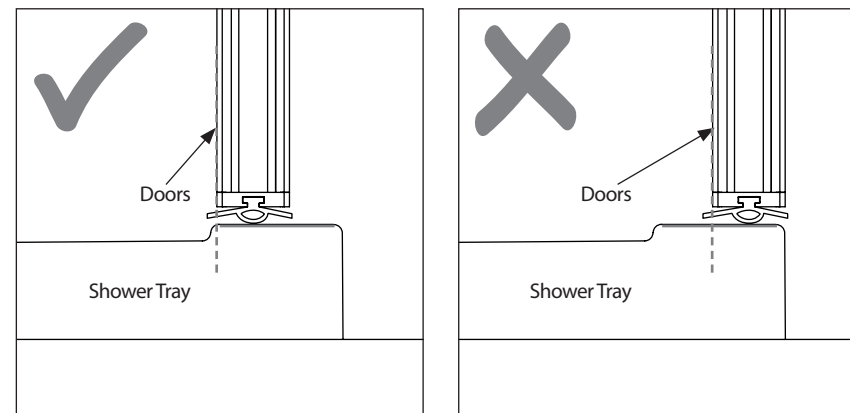

PLEASE NOTE:

Our compensators have a reasonable allowance for out of square walls, however in extreme cases it may be necessary to pack off the walls first.

The curtain rail may require to be trimmed because if the rail is wrongly sized it will pull or push the vertical support post out of alignment.

Finally when applying silicone ensure all non moving parts are sealed with silicone i.e. fixed panels, compensator, hinge block base and door catch.

Remember to advise the tenant/users to leave the silicone sealant to cure for at least 24 hours before using the shower.

1. Before drilling and fixing, slide fixed panel #2 into the aluminium extrusion on the corner post of fixed panel #1.

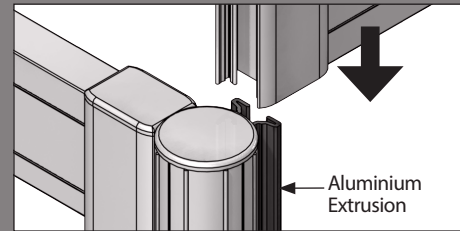

2. Set up the enclosure on the tray or wet floor. Ensure that the enclosure forms a perfect right angle and that the door seals are sitting fully on the seal platform of the tray, then mark the position of the compensators on the wall with a pencil.

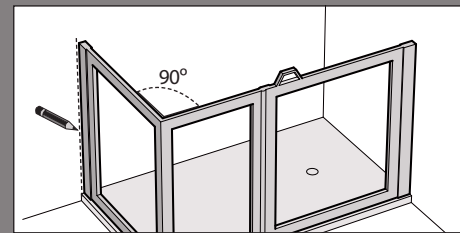

3. Using a spirit level, ensure both compensators are vertical 90°, and mark the position of the compensators' locating slots on the wall panels/tiled walls with a pencil.

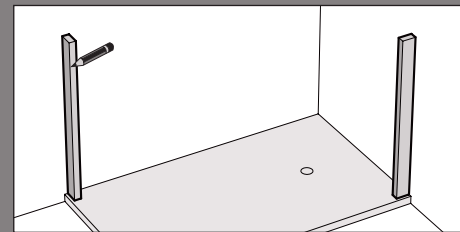

4. Using a 6mm masonry drill bit, drill the pilot holes for the compensators into the walls and then fit the 6 rawl plugs.

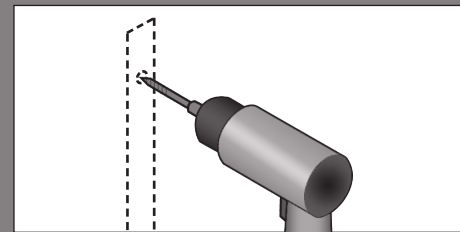

5. Using 6 of the 3.5mm x 35mm pozi-drive fixing screws supplied, realign compensators and drive screws home ensuring compensators are vertical 90°.

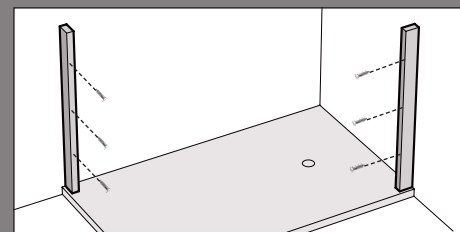

6. Re-fit the doors 'dry' and recheck the levels and contact of the seals on the tray. To plot the position for the correct placement of the fixed panels, mark centre lines at the bottom of the vertical support post and the post on the outermost corner of the tray or wet floor.

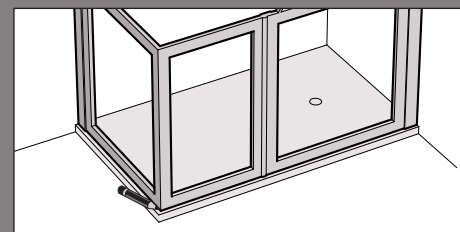

7. Remove the doors and extend these centre lines to mark 2 centre spots and then drill 2 pilot holes with the supplied 3mm drill bit.

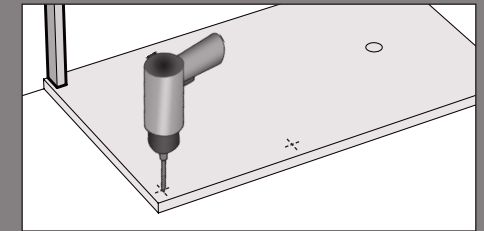

8. Position the 2 supplied locating discs over the pilot holes and using 2 of the 3.5mm x 22mm screws supplied, drive the screws home to secure the locating discs in place.

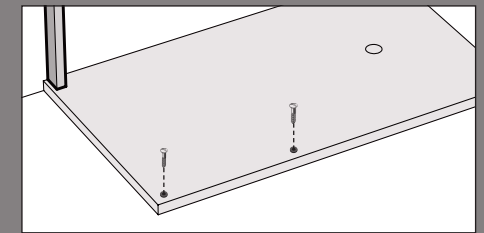

9. Apply a fine bead of the supplied silicone around the 2 locating discs and then position the fixed panel assembly into its compensator and over the locating discs.

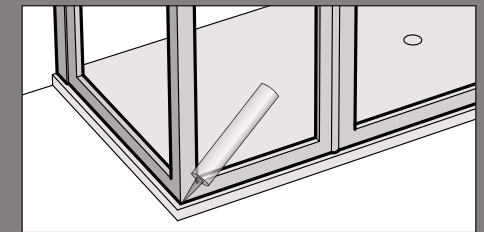

10. Slot the top half of the vertical support post over the square locating peg and secure the post in place using 2 of the 3.5mm x 22mm screws and 2 screw cap covers.

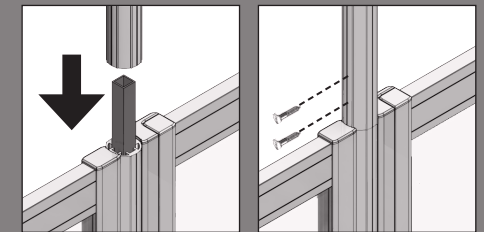

11. With the 3mm drill bit supplied, drill into the doors through all 8 compensator pilot holes, two on each side of each compensator.

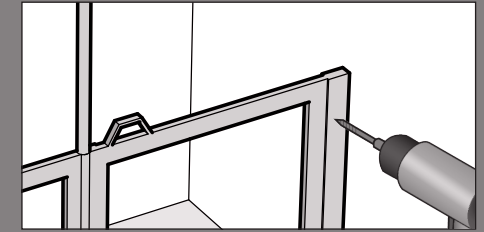

12. Using the 8 supplied 3.5mm x 12mm pozi-drive fixing screws with the 8 supplied screw cap covers secure the door panels into their respective compensators. Re-check the doors to ensure proper opening and closing.

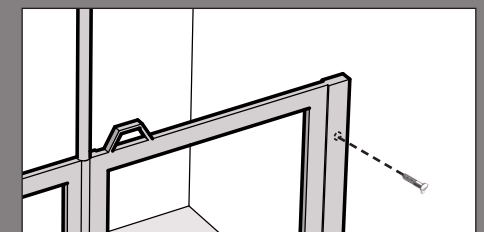

- Check sizes and if necessary use a handsaw to cut the curtain rail to the correct size to ensure the shower curtain will hang neatly inside the doors.

NOTE: When connecting the rail using the grab post 'top hat', some care must be employed to ensure that the post remains plumb to 90°. An undersized or oversized rail will pull or push the post off the plumb, which can have a negative bearing on how the door closes and seals with the magnetic retainer.

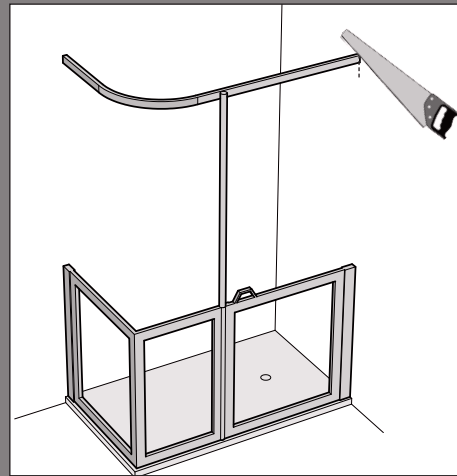

- Slide the 'top hat' connector into the top of the curtain rail.

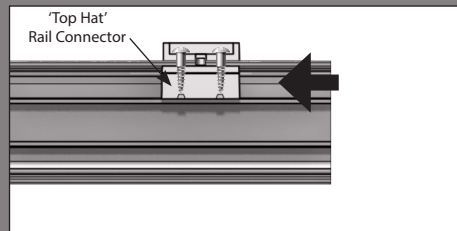

- Push the 'top hat' into the top of the vertical support post. Slide the curtain rail into the correct position and tighten the 2 flange panhead 9.5mm screws.

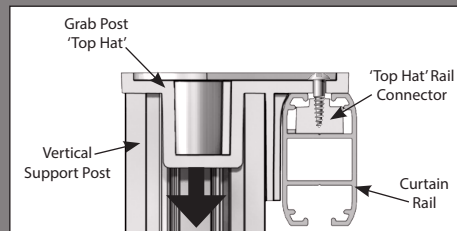

- Using a pencil, mark the position of the wall brackets at either end of the rail and drill holes in the wall. Using the 3.5mm x 35mm screws and cap washers, secure the brackets to the wall.

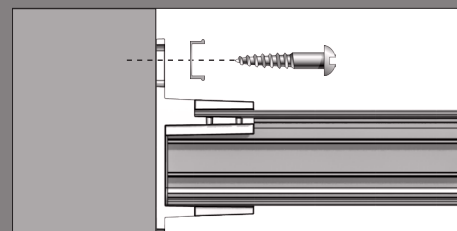

- Insert the supplied hooks & gliders into the bottom of the curtain rail, insert an anchor piece & hook into one of the wall brackets, and then hang the shower curtain from these fittings.

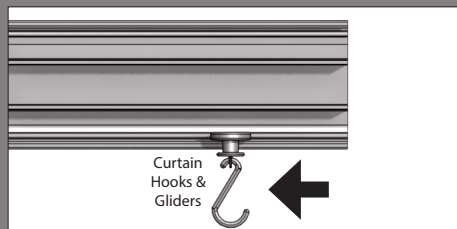

- Adjust the height of the curtain rail to the optimum height ensuring the shower curtain just sits off the tray.

NOTE: If the shower curtain folds onto the tray it may present a trip hazard.

- If installing a ceiling drop rod, insert the drop rod rail attachment into the top of the curtain rail.
NOTE: If fitting a U-shaped rail, we recommend installing 2 ceiling drop rods (as supplied).

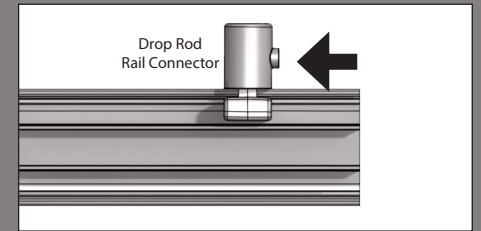
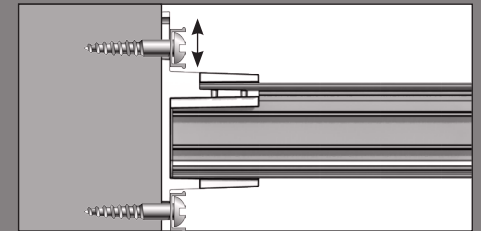

- If installing a ceiling drop rod, secure the ceiling attachment in the correct position on the ceiling using the remaining 3.5mm x 35mm screw.

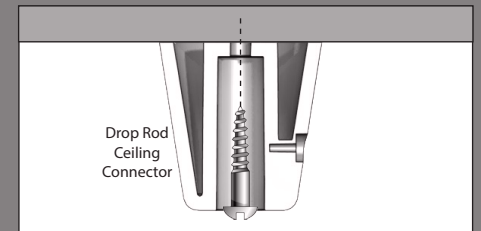

- Cut the drop rod to the correct length and insert the drop rod into the 2 connectors. Then, using the short 3mm screws, fasten each of the connectors to the drop rod.

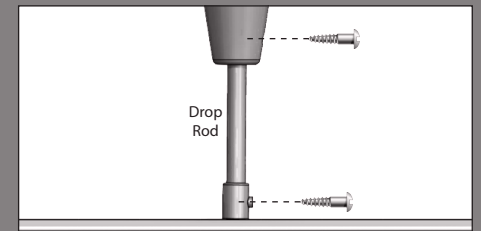

- When happy with the position and levels of the curtain rail, secure it in place using 2 of the flange panhead 9.5mm screws for each bracket. Snap the screw cover caps onto the existing washers to hide the exposed screws heads.

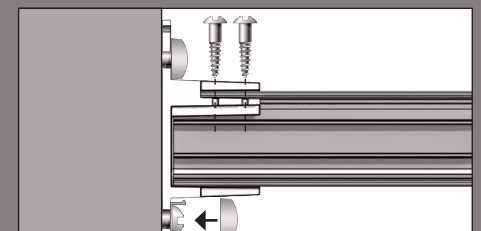

- Apply a small amount of silicone to the top of each door between the compensators and snap fit the compensator caps in place.

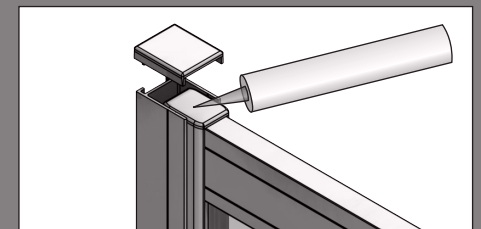

24. Ensure all non-moving parts are sealed with the silicone supplied, i.e. compensators inside and out. Ensure the bottom of the rise and fall hinges are significantly sealed with silicone.

25. Inform customers to let silicone cure for at least 24 hours prior to the use of a shower.

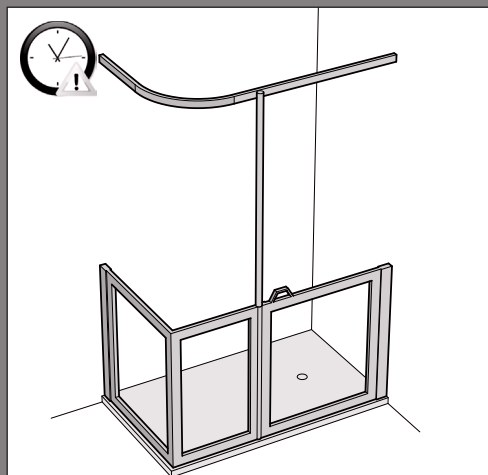
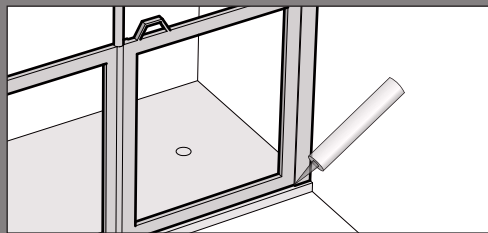

Adaptocare Limited

244 Nuneaton Street
Glasgow
G40 3DX

t: 0141 550 4177

f: 0141 554 4171

info@adaptocare.co.uk

www.adaptocare.co.uk